



C3100

# C3100 Speaker

## DESIGN FEATURES

- Compact, low profile design that works with all Code 3 sirens
- Produces low frequency tone with Banshee amp
- High efficiency
- Easy to install, grille mount
- Universal and vehicle specific mounting brackets

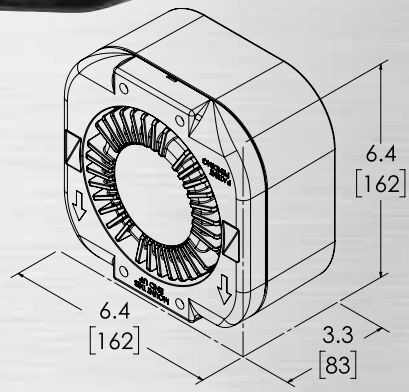

## SPECIFICATIONS

- 6.25"W x 3.25"D x 6.25"H (159 x 83 x 159 mm)
- 100 watt
- Meets SAE J1849 and California Title 13 requirements when used with Code 3 sirens
- 5-year warranty on driver

	Caprice 2011 +	Charger PPV 2011-14	Charger 2015	Crown Vic 2006-2011	Interceptor Sedan 2011 +	Interceptor Utility/Explorer 2011 +	Expedition 2007+	Explorer 2006-2010	Impala 2006+	Tahoe 2007-14	Tahoe 2015+
Behind the Grille Bracket	C3100CP	C3100CH11	C3100CH15	C3100CV2	C3100PI	C3100-PIU	C3100EN07	C3100FX1	C3100IM3	C3100TH1	C3100TH15
Second Speaker Bracket			C3100CH15-2		C3100PI-D	C3100-PIU2			C3100IM4	C3100TH1-D	C3100TH15-2
Other Brackets			C3100CH15-LM			C3100-FX2 (3)			C3100IM4-2		

See the Code 3 pricebook or bracket button on the Code 3 home page for siren bracket information.



PB100C

# PB100 Speaker

## Rugged chrome siren speaker

Speakers with American drivers are lightweight, rugged, and weather-resistant plus meet all Class A sound output requirements.

## DESIGN FEATURES

- Compact, low profile design
- High efficiency
- Easy to install, grille mount
- Vehicle specific mounting bracket

## SPECIFICATIONS

- 6.9"W x 5.2"D x 6.3"H (175 x 132 x 160 mm)
- 100 Watt
- Meets SAE J1849, and California Title 13 requirements when used with Code 3 siren
- 5-year warranty on driver

