

INSTALLATION GUIDE

C3100 Speaker Mtg Kit 2015 Tahoe

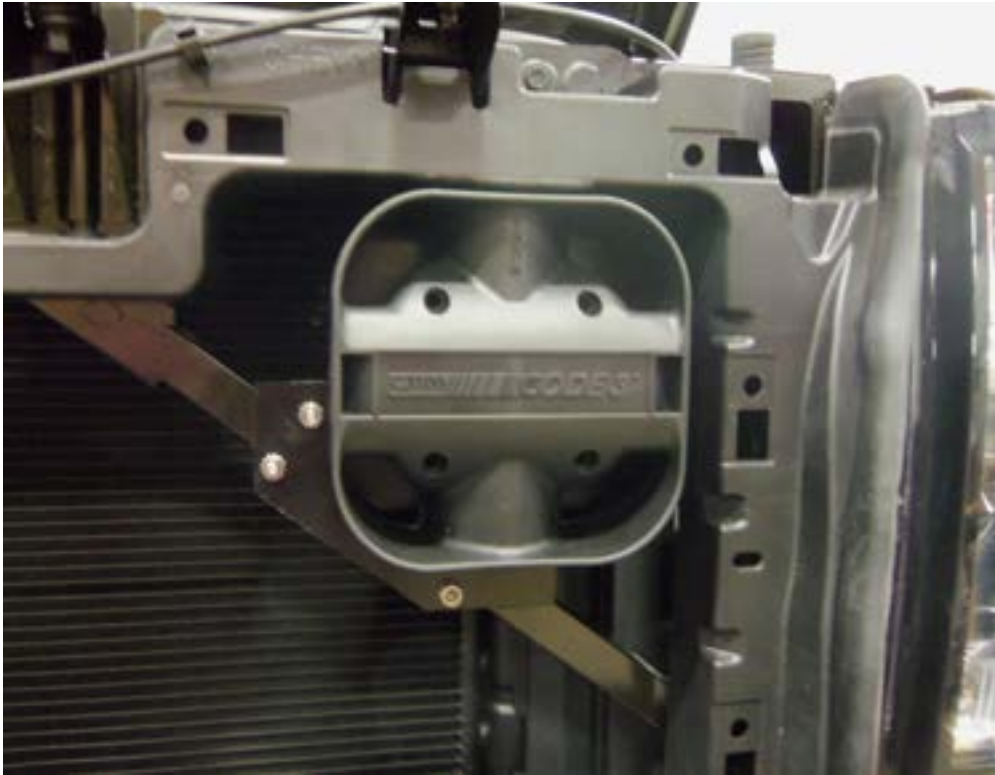

CODE 3[®]
A PUBLIC SAFETY EQUIPMENT COMPANY

⚠ WARNING



Sirens produce loud sounds that may damage hearing

- Wear hearing protection when testing
- Use siren only for emergency response
- Roll up windows when siren is operating
- Avoid exposure to the siren sound outside of vehicle

IMPORTANT:

Read all instructions and warnings before installing and using this equipment.

INSTALLER *This manual must be delivered to the end user of this equipment.*

Installation:

Step-1. Remove the plastic engine shroud.



Step-2. Remove the entire vehicle grill and front fascia assembly per shop manual instructions. Several fasteners are hidden so the shop manual is very helpful.



Step-3. Assemble the C3100 speaker/driver assembly to the mounting bracket as shown. Fasteners are with the C3100 speaker kit. Driver's side mount is shown. Reverse the mounting bracket for passenger side mount. Note the arrows must point up for water to drain properly from the speaker/driver assembly. Be sure the blue and white wires are connected to the driver.

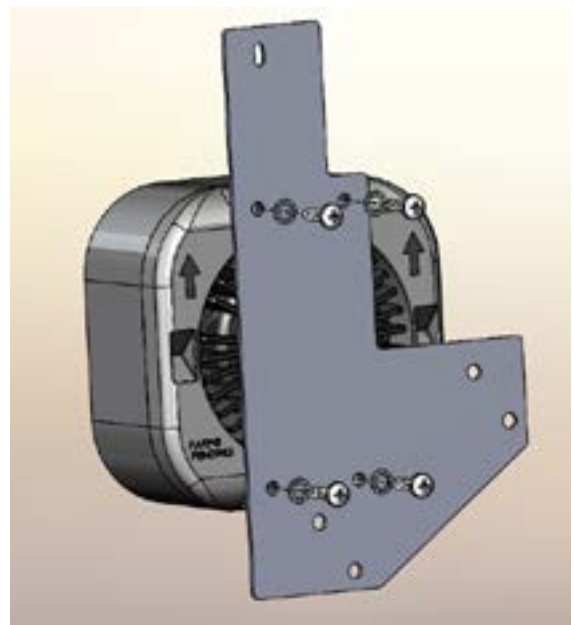

Step-4. Remove the indicated screw from frame shroud as shown below, pry open a gap and insert speaker/ bracket assembly. Reinstall the screw but do not tighten. Use the corresponding screw on the passenger side for passenger side speaker mount.



Step-5. Install 2 U-Bolts as shown using .25-20 hex nuts from the mounting kit. Recheck the speaker/driver assembly is mounted in the up position (so water will drain properly) and connect the blue and white wires to the siren amplifier per the siren and speaker driver instructions. Test for proper operation.



Step-2. Replace the vehicle grill and front fascia assembly per shop manual instructions. Reinstall the plastic engine shroud.



WARNING!
SIREN PRODUCTS:

Sirens are an integral part of an effective audio/visual emergency warning system. However, sirens are only short range secondary warning devices. The use of a siren does not insure that all drivers can or will observe or react to an emergency warning signal, particularly at long distances or when either vehicle is traveling at a high rate of speed. Sirens should only be used in a combination with effective warning lights and never relied upon as a sole warning signal. Never take the right of way for granted. It is your responsibility to be sure you can proceed safely before entering an intersection, driving against traffic, or responding at a high rate of speed. The effectiveness of this warning device is highly dependent upon correct mounting and wiring. Read and follow the manufacturer's instructions before installing or using this device. The vehicle operator should check the equipment daily to insure that all features of the device operate correctly.

To be effective, sirens must produce high sound levels that potentially can inflict hearing damage. Installers should be warned to wear hearing protection, clear bystanders from the area and not to operate the siren indoors during testing. Vehicle operators and occupants should assess their exposure to siren noise and determine what steps, such as consultation with professionals or use of hearing protection should be implemented to protect their hearing. This equipment is intended for use by authorized personnel only. It is the user's responsibility to understand and obey all laws regarding emergency warning devices. The user should check all applicable city, state and federal laws and regulations.

Code 3[®], Inc., assumes no liability for any loss resulting from the use of this warning device. Proper installation is vital to the performance of the siren and the safe operation of the emergency vehicle. It is important to recognize that the operator of the emergency vehicle is under psychological and physiological stress caused by the emergency situation. The siren system should be installed in such a manner as to: A) Not reduce the acoustical performance of the system, B) Limit as much as practical the noise level in the passenger compartment of the vehicle, C) Place the controls within convenient reach of the operator so that he can operate the system without losing eye contact with the roadway.

Emergency warning devices often require high electrical voltages and/or currents. Properly protect and use caution around live electrical connections. Grounding or shorting of electrical connections can cause high current arcing, which can cause personal injury and/or severe vehicle damage, including fire.

PROPER INSTALLATION COMBINED WITH OPERATOR TRAINING IN THE PROPER USE OF EMERGENCY WARNING DEVICES IS ESSENTIAL TO INSURE THE SAFETY OF EMERGENCY PERSONNEL AND THE PUBLIC.

WARRANTY

Code 3, Inc.'s emergency devices are tested and found to be operational at the time of manufacture. Provided they are installed and operated in accordance with manufacturer's recommendations, Code 3, Inc. guarantees all parts and components except the lamps to a period of 1 year, LED Lighthead modules to a period of 5 years (unless otherwise expressed) from the date of purchase or delivery, whichever is later. Units demonstrated to be defective within the warranty period will be repaired or replaced at the factory service center at no cost.

Use of lamp or other electrical load of a wattage higher than installed or recommended by the factory, or use of inappropriate or inadequate wiring or circuit protection causes this warranty to become void. Failure or destruction of the product resulting from abuse or unusual use and/or accidents is not covered by this warranty. Code 3, Inc. shall in no way be liable for other damages including consequential, indirect or special damages whether loss is due to negligence or breach of warranty.

CODE 3, INC. MAKES NO OTHER EXPRESS OR IMPLIED WARRANTY INCLUDING, WITHOUT LIMITATION, WARRANTIES OF FITNESS OR MERCHANTABILITY, WITH RESPECT TO THIS PRODUCT.

PRODUCT RETURNS

If a product must be returned for repair or replacement*, please contact our factory to obtain a Return Goods Authorization Number (RGA number) before you ship the product to Code 3, Inc. Write the RGA number clearly on the package near the mailing label. Be sure you use sufficient packing materials to avoid damage to the product being returned while in transit.

*Code 3, Inc. reserves the right to repair or replace at its discretion. Code 3, Inc. assumes no responsibility or liability for expenses incurred for the removal and for installation of products requiring service and/or repair, nor for the packaging, handling, and shipping, nor for the handling of products returned to sender after the service has been rendered.

NEED HELP? Call our Technical Assistance HOTLINE - (314) 996-2800

Code 3®, Inc. 10986 N. Warson Road St. Louis, Missouri 63114-2029—USA Ph. (314) 426-2700 Fax (314) 426-1337
www.code3pse.com